

Bleed Piloted 4-Way Valve

Pressure in line 4 pilots valve V2 so that the cylinder is retracted on the valve V-2 and C-1 retracted. When V-1 is actuated, the pressure is exhausted from 4 faster than the restricted supply at 5 can make it up. The spring then shifts the valve and C-1 extends.

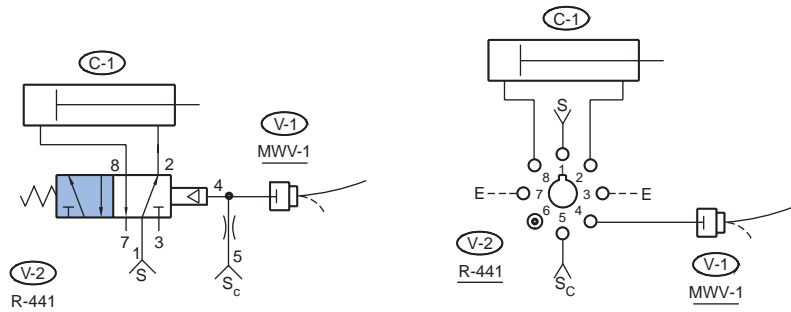

Unique OPEN-CLOSE Pulse Circuit

This pulse circuit can be adapted to a wide variety of uses. It consists of an MAV-3 3-way valve and two standard R-341 modular valves, and is being used to open and close a collet vice on a milling fixture. Circuit operation: when V-1 is depressed, V-2 gives an output pulse at "A". The length of the pulse is predetermined by the needle valve adjustment on V-2.

When V-1 is released, a pulse occurs at "B".

This pulse is also determined by the length of the needle valve on V-3. Thus both pulses are independently adjustable. Note that the R-341 allows supply to be segregated from the pilot signal which allows for different pressures or gases to be controlled.

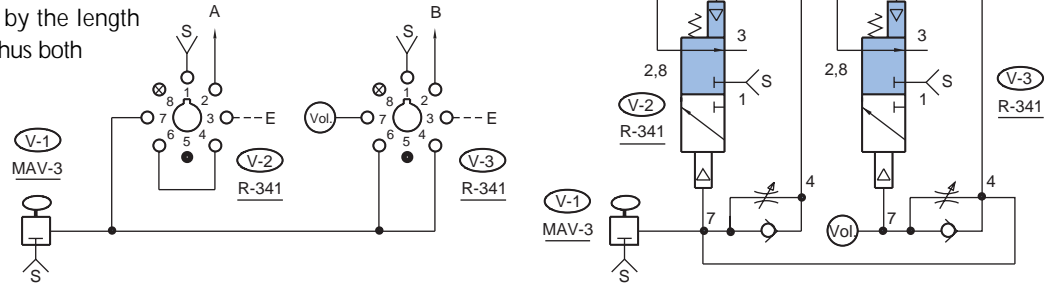

"Latch" Circuit

Actuation of V-1 pilots V-3 and extends C-1. The same pressure that extends C-1 also passes through V-2 and holds the twin pilot down locking C-1 in the out position even though V-1 is released. When V-2 is actuated, breaking the line between port 2 & 5, V-3, and exhausting the pilot, the spring will shift the valve V-3, causing C-1 to retract.

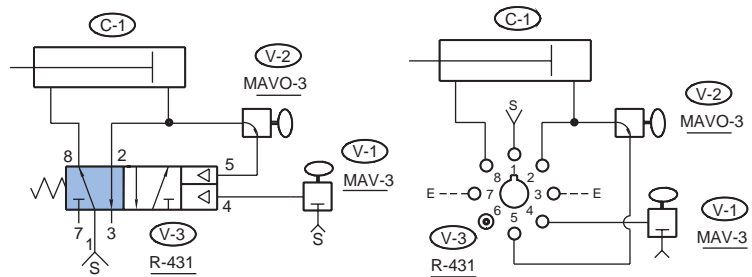

"Active Or" Circuit

Actuation of any one or all of the input signal valves, V-1, V-2, V-3, V-4, will cause an active output (an output from a separate air supply source).

